

# SUPERVISION®



"I could not believe how the front door of the residence was now in perfect sight which I was not able to determine with my naked eye. With my naked eye I was not even able to see that multiple doorways existed. Now with the SuperVision in use I was able to see the suspect, observe the exact doorway that was being used by the suspect, the number on the doorway and vehicle registrations that were associated with this residence. This was all done from inside my under-cover vehicle."

## SuperVision

*"When something's going down in the dark, I need to be close enough to identify the subject or situation without being compromised."* For law enforcement professionals like you, you've got to be close enough to identify exactly what's happening, but not compromise yourself or your operation. SuperVision gives you crystal clear images in any lighting condition, to get you the situational awareness, intelligence and the evidence you need to do it right and make it stick.

## The Tactical Edge

SuperVision is built on an entirely new, patented technology. Xenonics' engineers have taken solid-state, wide-dynamic range imaging to next level of sophistication with the application of digital signal processing (DSP) & image enhancement software that brings otherwise indistinguishable forms into sharp identifiable objects. This advanced technology, built in SuperVision, gives law enforcement the tactical edge they need to identify people and objects with crystal clarity.

## SuperVision -- a Class by Itself

Unlike most post Desert Storm Gen I, Gen II or Gen III image intensified night vision devices that have been adopted for law enforcement, SuperVision has been built from the ground up, especially designed for officers and agents and their special requirements in an increasing dangerous urban environment. While there are plenty of night vision and thermal imaging products on the market, only SuperVision is so unique that it's in a class by itself.

## Key Features

- Low-Light CCD Sensor
- 2-8x Zoom Capability
- Digital Signal Processing
- HDTV Display
- Battery Runtime: 2 hours
- Rechargeable Li-ion Battery
- Smart Digital Battery Charger
- Lightweight, Ruggedized
- Patented Technology

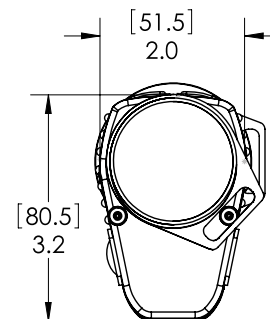
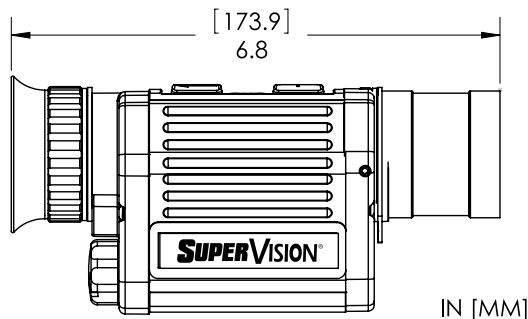

## Uses and Applications

SuperVision is designed to give law enforcement officers and agents the edge at night, whether on patrol, in pursuit, search & rescue, surveilling, no matter what the night may bring. From gathering intelligence to recording evidence, see the details you need in the dark or shadows, from a safe distance.

## The Difference is Black and White

In field tests, operators report significantly better degrees of detail, overall contrast, full moon similarity and range of shades with SuperVision. That's because SuperVision provides more discriminating shades of intensity between black and white, resulting in better contrast and depth perception.



## To See and Not Be Seen

SuperVision's 2-8X variable zoom gets you close without actually getting close with the capability to identify subjects and objects even with bright light in dark settings without blooming from a safe distance, without compromise.

## Protect & Serve 24-Hours a Day

SuperVision's revolutionary wide-dynamic range imaging platform, with proprietary digital signal processing, let's you identify what you need, no matter the conditions, from total darkness, to full daylight, and even with bright lights in otherwise dark situations.

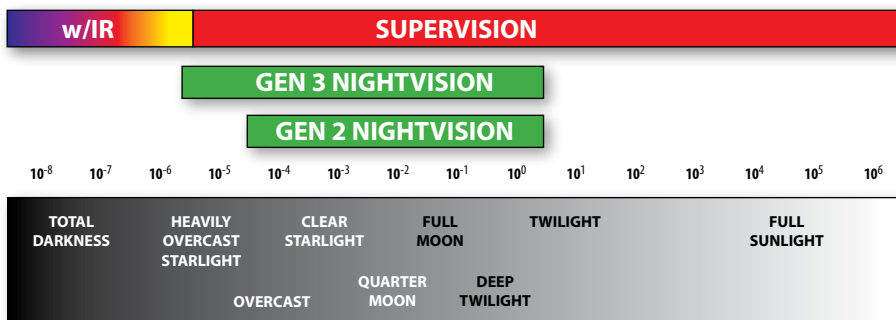

## World Class Development and Manufacturing

Xenonics Holdings, Inc. (NYSE AMEX:XNN) is the world's leader in the development and manufacturing of advanced, lightweight and compact ultra-high intensity illumination and low-light viewing products for the military, law enforcement and public safety.

## System Specifications

Sensor	1/2" CCD mono
Near Eye Display	0.55" LCOS mono
CCD Total Pixels	811(H) X 508 (V)
Display Total Pixels	1280 (H) x 720 (V)
Aspect Ratio	16:9
Magnification	2X fixed
Digital Zoom	4X
Focus Range	6" [15 cm] to infinity
Minimum Illumination	0.00005 lux
Light Sensitivity	300 to 1050 nm
Diopter Adjustment	yes, factory set
<b>Power Supply</b>	
Battery Type	Li-Ion 18650 2200mAh Circuit-protected
Battery Runtime	2 hours
Operating Voltage	2.8 to 4.2 VDC
Battery Life (Rechargeable)	500 cycles
Immersion	1 meter
Operating Temperature	-20° to 60°C
<b>Mechanical Features</b>	
Mounting	1/4" X 20
Length	6.8" [173.9 mm]
Height	3.2" [80.5 mm]
Width	2.0" [51.5 mm]
Weight	20 oz [567 g]



888-603-4004  
[www.xenonics.com](http://www.xenonics.com)  
[customerservice@xenonics.com](mailto:customerservice@xenonics.com)

3186 Lionshead Ave.  
 Carlsbad, CA 92010  
 Phone: 760.477.8900  
 Fax: 760.477.8899